

SURVEYOR'S CERTIFICATE

I, Lieb Dee Miller, DO HEREBY CERTIFY THAT I AM A REGISTERED Land Surveyor AND THAT I HOLD CERTIFICATE NO. 22-5527 AS PRESCRIBED UNDER THE LAWS OF THE STATE OF UTAH. I FURTHER CERTIFY BY AUTHORITY OF THE OWNERS, I HAVE MADE A SURVEY OF THE TRACT OF LAND SHOWN ON THIS PLAT AND DESCRIBED BELOW, AND HAVE SUBDIVIDED SAID TRACT OF LAND INTO LOTS, BLOCKS, STREETS, AND EASEMENTS AND THE SAME HAS BEEN CORRECTLY SURVEYED AND STAKED ON THE GROUND AS SHOWN ON THIS PLAT AND THAT THIS PLAT IS TRUE AND CORRECT.

BOUNDARY DESCRIPTION

COMMENCING Beginning of the NW corner of the NE 1/4 of the NW 1/4 of Section 26, Township 17 South, Range 8 East SALT LAKE BASE & MERIDIAN; THENCE AS FOLLOWS:

COURSE	DISTANCE	REMARKS
N 89° 00' E	660.0	
S 0° 00' E	701.25	
N 89° 00' W	660.0	
N 0° 00' W	701.25	

This notation was placed on wrong corner.

R. Swasey
Recorder

DATE 2-28-77 SURVEYOR Lieb Dee Miller
(See Seal Below)

OWNERS' DEDICATION

KNOW ALL MEN BY THESE PRESENTS THAT WE, ALL OF THE UNDERSIGNED OWNERS OF ALL OF THE PROPERTY DESCRIBED IN THE SURVEYOR'S CERTIFICATE HEREON AND SHOWN ON THIS MAP, HAVE CAUSED THE SAME TO BE SUBDIVIDED INTO LOTS, BLOCKS, STREETS AND EASEMENTS AND DO HEREBY DEDICATE THE STREETS AND OTHER PUBLIC AREAS AS INDICATED HEREON FOR PERPETUAL USE OF THE PUBLIC.

IN WITNESS WHEREOF WE HAVE HEREUNTO SET OUR HANDS THIS 24 DAY OF Feb, A.D. 1977.

Robert Powell
Thomas Powell

ACKNOWLEDGEMENT

STATE OF UTAH } S.S.
COUNTY OF Emery }
ON THE 24 DAY OF Feb, A.D. 1977 PERSONALLY APPEARED BEFORE ME THE SIGNERS OF THE FOREGOING DEDICATION WHO DULY ACKNOWLEDGE TO ME THAT THEY DID EXECUTE THE SAME.
MY COMMISSION EXPIRES March 5, 1980 *Maureen S. Magnuson*
NOTARY PUBLIC
(See Seal Below)

ACCEPTANCE BY LEGISLATIVE BODY

THE PLANNING COMMISSION OF THE COUNTY OF Emery, UTAH, APPROVES THIS SUBDIVISION AND HEREBY ACCEPTS THE DEDICATION OF ALL STREETS, EASEMENTS, AND OTHER PARCELS OF LAND INTENDED FOR PUBLIC PURPOSES FOR THE PERPETUAL USE OF THE PUBLIC THIS 11 DAY OF Aug, A.D. 1976.

Robert O. Desautels *Scott Wilson*
John Chapman
Kenneth O. Mademan
APPROVED: Maureen S. Magnuson ATTEST: Bertha Jones
ENGINEER (See Seal Below) CLERK-RECORDER (See Seal Below)

BOARD OF HEALTH

APPROVED SUBJECT TO THE FOLLOWING CONDITIONS:

CITY-COUNTY HEALTH DEPARTMENT

PLANNING COMMISSION APPROVAL

APPROVED THIS 11 DAY OF August, A.D. 1976 BY THE PLANNING COMMISSION
Sala Morgan *Julia B. Hall*
DIRECTOR-SECRETARY CHAIRMAN, PLANNING COMMISSION

PLAT " "

JAY POWELL

SUBDIVISION

SCALE: 1" = 50 FEET

UTAH COUNTY, UTAH

SURVEYOR'S SEAL	NOTARY PUBLIC SEAL	CITY-COUNTY ENGINEER SEAL	CLERK-RECORDER SEAL
-----------------	--------------------	---------------------------	---------------------

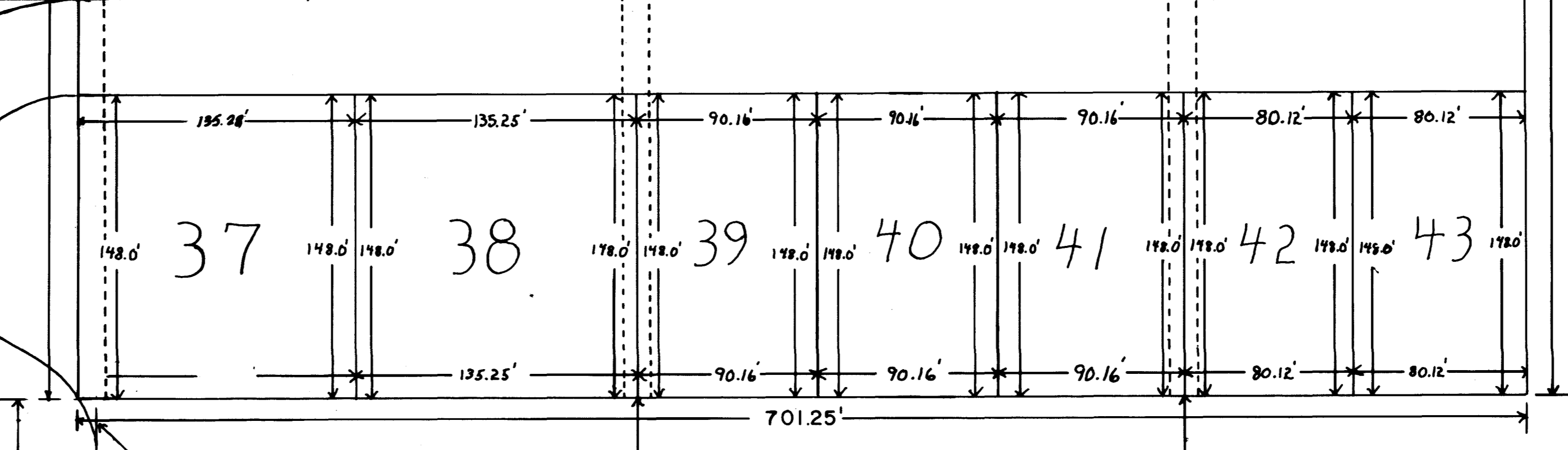
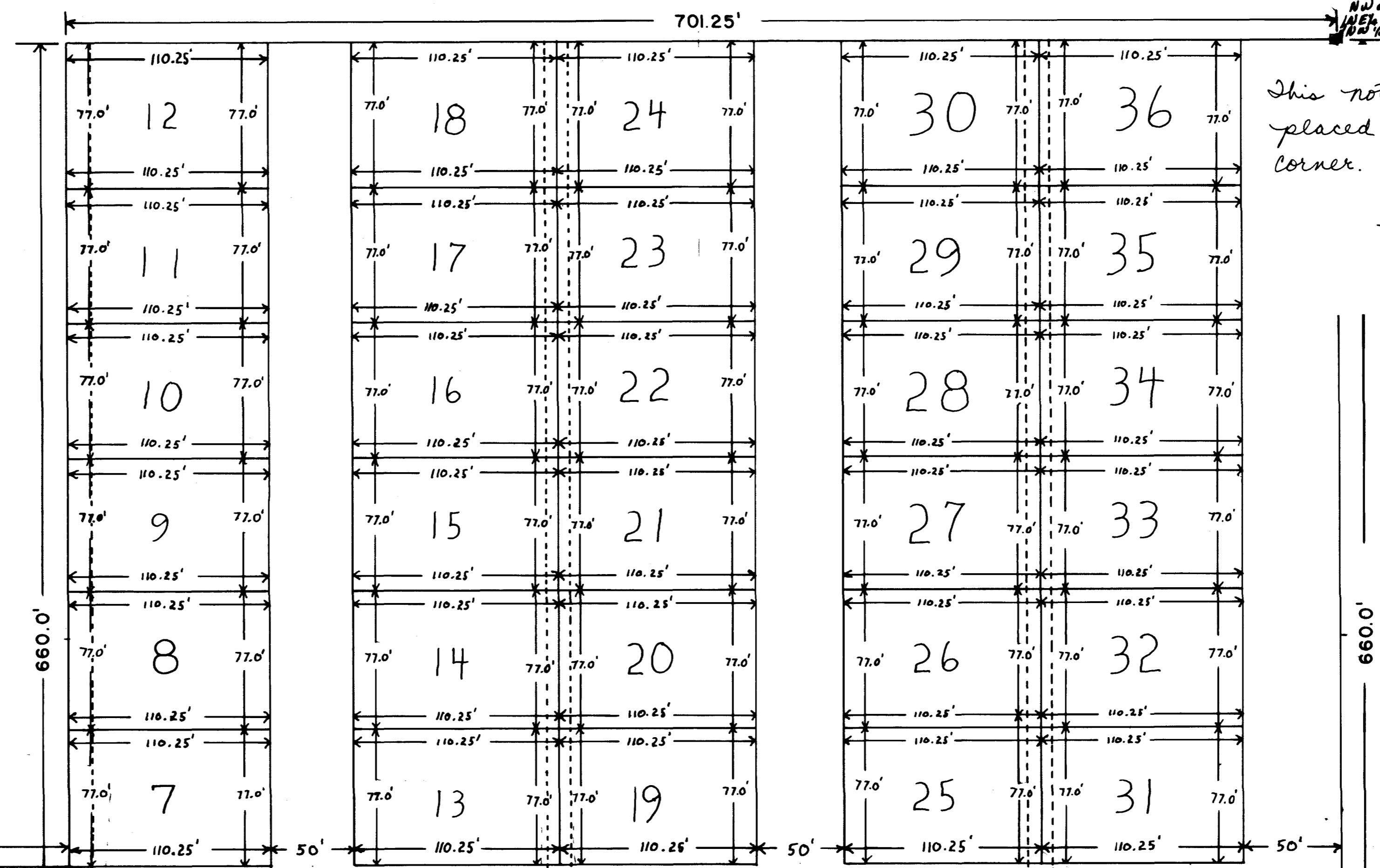

UTAH POWER AND LIGHT 14' FOOT RIGHT-OF-WAY THROUGH SUBDIVISION

50' RIGHT-OF-WAY ON CITY PROPERTY